

**CRAFCO**™  
AN ERGONE COMPANY  
**INC**

**SUPER SHOT 125 MELTER  
WITH AIR COMPRESSOR**

# SUPER SHOT 125 MELTER WITH AIR COMPRESSOR

This manual is furnished with each new CRAFCO™ SUPER SHOT 125 MELTER. The manual will help your machine operators learn to run the sealer properly and understand its mechanical functions for trouble-free operation.

Your CRAFCO™ SUPER SHOT 125 MELTER is designed to give excellent service and save maintenance expense. However, as with all specially engineered equipment, you can get best results at minimum costs if:

- a. You operate your machine as instructed in this manual.
- b. Maintain your machine regularly as stated in this manual.

**WARNING:** The Engine Exhaust from this product contains chemicals known to the State of California to cause cancer, birth defects or other reproductive harm. Operate in well ventilated area only. engine Exhaust is deadly.

## TABLE OF CONTENTS

Safety Precautions	2
Warranty	3
Warranty Claim Instructions	3
Specifications	4
Operating Instructions	5
Machine Start Up	6
Air Compressor	7
Dispensing The Material	7
Inlet Filter / Strainer	7
Loading Machine	8
Shutdown And Clean-out Procedure	8
Storing Machine	8
Instructions For Ordering Parts	9
Electric Hose Care And Cautions	9
Hose Transport Instructions	10
<b>Maintenance</b>	
Maintenance Instructions	11
Maintenance Chart	11
Recommended Fluids And Lubricants	12
Warning For Heat Transfer Oil And All Oils	12
Material Pump Replacement	13
Unloader Valve Adjustment	15
<b>Trouble Shooting</b>	
Wiring Schematic	16
How to Check Hose And Wand	17
Hose Trouble Shooting	18
Burner Schematic	19
Burner Trouble Shooting Guide	20
Trouble Shooting Hydraulics	21
Hydraulic Schematic	22-25
<b>Parts</b>	
SS 125 Parts Diagram	26,28
SS 125 Parts List	27,29
Tank Diagram	30
Tank Parts List	31
Control Box Assembly	32
Control Box Parts List	33
Engine Assembly	34
Engine Assembly Parts List	35
Hydraulic Valve Assembly	36
Pump / Agitator Assembly	37
Compressor Assembly	38
Compressor valve Assembly	39

## SAFETY PRECAUTIONS

- \* High operating temperatures of Sealant and Machine require protective clothing, hard soled shoes, and heat resistant gloves be worn by operator.
- \* Always wear eye protection.
- \* Observe all **CAUTION AND WARNING** signs posted on machine.
- \* Avoid the entrance of water into any part of the machine. Water will displace heat transfer oil or sealant which could be hazardous to personnel surrounding the machine when it reaches operating temperatures.
- \* Avoid bodily contact with hot sealant material or heat transfer oil, serious burns may result.
- \* Read Operator Manual thoroughly before operating machine.
- \* Make sure operator is familiar with machine operation.
- \* Shut-down burner and engine prior to refilling Diesel Tank.
- \* When adding solid material to Sealant Tank, lift lid, placed material onto lid and close lid. Hot material could splash and cause serious burns if this procedure is not followed.
- \* Keep hands, feet, and clothing away from all moving parts.
- \* Always keep a fire extinguisher near the unit. Maintain extinguisher properly and be familiar with its use.
- \* **DO NOT** exceed 525° F. for heat transfer oil temperature.
- \* **DO NOT** overfill heat transfer oil level. Expansion of oil during heat up could cause overflow. Check oil each day before starting burner, add oil to full mark on dipstick (at 70° F.). Use only recommended heat transfer oil and change after 500 hours of operation or one year, whichever occurs first.
- \* Follow operating instructions for starting and shut-down of burner. See operating instructions.
- \* Calibrate temperature control prior to initial operation and each 50 hours of operation.
- \* Replace any hoses which show signs of wear, fraying, or splitting. Be sure all fittings and joints are tight and leak proof.
- \* Precaution is the best insurance against accidents.
- \* The melter should not be left unattended with the burner lit.
- \* Tighten all bolts and screws after every 100 hours of operation.
- \* CRAFCOR™, INC., assumes no Liability for an accident or injury incurred through improper use of the machine.
- \* Refer to Compressor Manual for operating procedures and safety precautions.

## LIMITED WARRANTY

Crafco™, Inc., through its authorized distributor, will replace for the original purchaser free of charge any parts found upon examination by the factory at Mesa, Arizona, to be defective in material or workmanship. This warranty is for a period within 60 days of purchase date, but excludes engine or components, tires, and battery as these items are subject to warranties issued by their manufacturers.

After 60 days, Crafco™, Inc., warrants structural parts, excluding heating system, hydraulic components, material pump and hoses, hot oil pump, applicator valves, and electrical components for a period of (1) one year from date of delivery. Crafco™, Inc., shall not be liable for parts that have been damaged by accident, alteration, abuse, improper lubrication/maintenance, normal wear, or other cause beyond our control.

The warranty provided herein extends only to the repair and/or replacement of those components on the equipment covered above and does not cover **labor** costs. The warranty does not extend to incidental or consequential damages incurred as a result of any defect covered by this warranty.

All transportation and labor costs incurred by the purchaser in submitting or repairing covered components must be bore by the purchaser.

Crafco™, Inc., specifically disavows any other representation, warranty, or liability related to the condition or use of the product.

**Warning** - Use of replacement parts other than genuine Crafco™ parts may impair the safety or reliability of your equipment and nullifies any warranty.

## WARRANTY CLAIM INSTRUCTIONS

Please follow the instructions stated below when calling in a Warranty Claim. Failure to follow these procedures may be cause to void the warranty.

1. Call you local Crafco™ Distributor. If you do not know who your local distributor is, call a Crafco™ Customer Service Representative, (Toll Free 1-800-528-8242) for name, location, and telephone number.
2. On contacting the Distributor, be prepared to identify the machine type, model number, and serial number, also, the date of purchase if available.
3. Should the cause of the malfunction be a defective part, the Distributor will advise you of the procedure to follow for a replacement.
4. The warranty is valid only for parts which have been supplied or recommended by Crafco™, Inc.

If you have any additional questions regarding warranty repairs and parts, please do not hesitate to call toll free 1-800-528-8242.

CRAFECO™, INC.  
235 S. HIBBERT DR.,  
MESA, AZ 85210  
(602) 655-8333  
Toll Free 1-800-528-8242

## SPECIFICATIONS

---

Vat Capacity	125 Gallons
Melt Capacity	90 Gallons/Hour
Heat Transfer Oil Required	34 Gallons at 70° F.
Tank Construction	Double Boiler Type
Tank Opening Size	14" X 18"
Maximum Heat Input	250,000 BTU's
Burner and Temperature Control	Diesel-Forced Air Thermostatic Control
Engine - Isuzu Model 3LD1 - Diesel	Three Cylinder 37 BHP @ 3,600 rpm
Hydraulic Drive Mechanism	All Hydraulic with infinite speed on Mixer and Material Pump
Mixer	Full sweep mixer with 2 horizontal paddles Vertical risers
Axle	Dual - Torsional
Tires (4)	185R-148 ply rating
Dry Weight	Approximately 4,020 lb.
Diesel Tank Capacity	32 Gallons
Air Compressor	84CFM Rated @ 90 PSI Air Pressure Setting

---

# SUPER SHOT 125 MELTER WITH AIR COMPRESSOR OPERATING INSTRUCTIONS

## INTRODUCTION

The CRAFCO™ SUPER SHOT 125 MELTER was developed to melt CRAFCO™ Brand Sealants. However, it will work equally well with all road asphalts and federal specification crack or joint sealants.

**DO NOT** operate machine without following these instructions:

- a. Fill fuel tank with diesel fuel (use #1 in cold weather, #2 in warm weather).
- b. Check engine crankcase oil level (refer to Engine Operator's Manual).
- c. Check hydraulic fluid level, at 70° F. Add fluid if necessary.
- d. Check heat transfer oil level. At ambient temperature, the oil should be at the full mark on the dipstick. **DO NOT** overfill or spillage may occur when oil is heated and expands.
- e. All toggle switches should be turned "OFF" and both temperature control dials at minimum settings.
- f. Remember that safe operation of this equipment is the operator's responsibility.
- g. Check oil in Compressor (Refer to Compressor Operator's Manual).

## CAUTION:

Extreme care must be used when operating this equipment. Safety is the result of being careful and paying attention to details. Remember the diesel flame is about 2,200° F. Certain exposed parts of this machine, when operating, reach 500° F.; the sealant as high as 400° F. and the hydraulic fluid may reach 200° F. Always wear protective clothing, hard soled shoes, and eye protection. Be sure that all joints and fittings are tight and leak proof. Immediately replace any hose which shows any signs of wear, fraying, or splitting. Tighten all bolts, nuts, and screws every 250 hours.

## MACHINE START UP

### TO START BURNER

1. Fully open the Damper Vent.
2. Start Engine per Engine Manual.
3. Turn toggle switch at control box "ON".
4. Set hot oil temperature at 500° F. and material temperature at manufacturers recommended temperature.

### CAUTION:

If burner does not ignite the first time, turn toggle switch off. Turn toggle switch to "ON". Burner should ignite. If burner still does not ignite, determine cause of malfunction (see Trouble Shooting Guide).

5. Allow the heating oil to continue to heat. When sealant material reaches a liquid state, engage the mixer by turning the toggle switch "ON". If the mixer does not move, allow the material to heat longer. Jamming of mixer causes hydraulic oil to overheat and machine damage could occur.
6. Turn "ON" the hose controller when hot oil temperature reaches approximately 300° F. See Operating Instructions. Adjust the temperature dial to 380 degrees. The hose will come up to temperature in approximately 30 minutes. After the hose is hot, the light in the control box marked "hose controller" will turn off and the temperature may be reduced to approximately 360 degrees. It is advisable to run the hose at the lowest temperature setting possible and still have material dispense.

**NOTE!!** The hose must be up to temperature before dispensing can take place.

**IMPORTANT!! DO NOT** twist or kink hose. Avoid sharp bends and continuous twisting. Maintain minimum 10 inch bend radius. **DO NOT** exceed 400 degrees setting on hose controller!! **DO NOT** move or bend hose when cold. Damage may result. **DO NOT** leave hose "ON" for longer than 30 minutes without dispensing material. Coking will occur and permanently damage hose.

**IT IS STRONGLY RECOMMENDED THAT THE HOSE BE STORED IN THE HOSE HANGER WHEN NOT IN USE OR WHEN IN TRANSIT. THIS WILL HELP PREVENT TWISTING OR KINKING.**

7. The heated hose supplied with the machine is Teflon lined with a nylon over braid. It has a heating element which runs down the hose to heat the material within the hose. The hose is covered with high temperature, durable rubber hose. The wand has an aluminum tube to protect both the wand and the operator. The pistol grip actuator is equipped with an electric switch which when depressed sends a signal to actuate the pump. At the end of the wand, a high temperature elastomeric output valve is attached. The valve is pressure actuated and opens automatically when fluid pressure is applied. The wand is equipped with a trigger lock to prevent accidental pump actuation when not pumping material. The trigger should be in the "LOCKED" position at all times except when intentionally pumping material.



## AIR COMPRESSOR

The air compressor unit installed on the Super Shot 125 is designed to assist in the cleaning of debris from cracks and joints. **Always** use approved high pressure air hoses with properly installed fittings. **Do Not Use Frayed or Worn Hoses.** A cold air lance, or approved hot air, or approved hot air lance can be used with this compressor.

For maximum air compressor performance, the engine should be operated at maximum factory set **R.P.M.**'s.

Consult Craftsco, or your hot air lance dealer for the appropriately sized lance used on a 84 CFM compressor.

The compressor is operated hydraulically and disengaged when maximum air pressure setting in storage tank is reach. If the compressor is not needed, turn off at toggle switch in control box.

---

## DISPENSING THE MATERIAL

**NOTE!! PROTECTIVE CLOTHING, GLOVES, HARD SOLED SHOES, AND FACE SHIELD OR SAFETY GLASSES SHOULD BE WORN WHEN OPERATING OR FILLING THIS EQUIPMENT. READ ENTIRE MANUAL BEFORE OPERATING.**

The wand is equipped with a disposable duckbill valve on the end which shuts off the flow of material when the pump is turned off and prevents excessive dripping of material. This valve also directs the material into a stream for easy application into the crack.

Some difficulty may be encountered when starting up on cold days. Although the wand is designed to heat the material all the way down to the tip, on cold days it may be necessary to place the tip of the wand under the lid to facilitate material melting in the valve. Insert the wand tip for only a short time before proceeding.

When the material and the hose have reached proper application temperature, you are ready to dispense material. Turn the pump speed control to the lowest setting by turning the speed control knob fully counter clockwise. With the wand tip inserted into the top of the melter, depress trigger on the wand and slowly increase pump speed by turning the speed control knob clockwise until the pump motor starts to turn. Material should start to flow from the tip of the duckbill valve. Adjust the pump speed for the desired rate of flow for the application and dispense material as required. The rate of flow may be varied while the pump is running by rotating the control knob.

**NEVER POINT WAND AT ANY PART OF THE BODY OR AT ANY OTHER PEOPLE.  
HOT MATERIALS CAN CAUSE SEVER BURNS. WEAR PROTECTIVE EQUIPMENT  
WHEN FILLING OR OPERATING THE EQUIPMENT. READ MANUAL BEFORE  
OPERATING EQUIPMENT.**

## INLET FILTER/STRAINER

The melter is equipped with an inlet filter/material strainer at the material pump. This strainer is attached to the mixer and rotates when the mixer is turning. The strainer keeps rocks and other foreign material from entering and plugging the hose or pump. No maintenance of this screen is required under normal operation.

## LOADING THE MACHINE

When loading solid material into the sealant tank, the mixer will stop when the lid is lifted.

To load, lift the lid, place the material on the lid and close lid. Following this procedure will prevent the hot material from splashing and causing serious burns to personnel.

The solid material must be added at intervals which will allow the mixer to rotate without jamming. If blocks of material are fed in too quickly, jamming will result and slow down the melting process.

## SHUTDOWN AND CLEAN-OUT PROCEDURE

When shutting down the machine for the day, there are several schools of thought about how much material to leave in the machine. Craftco™ recommends leaving the melter about half full. This will give a fairly rapid heat up rate in the morning, but will allow enough material to start dispensing right away when the material becomes molten.

1. Turn the burner control toggle switch "OFF".
2. Reverse the pump for approximately 30 seconds.
3. Turn the hose controller to "OFF".
4. Turn the hose controller toggle switch "OFF".
5. Store the hose in the hose hanger per transport decal on machine. **IMPORTANT!! DO NOT** kink or twist the hose as permanent damage will result.
6. Turn the mixer toggle switch to "OFF".
7. Shut the engine down by turning the key to the "off" position.

## STORING MACHINE

The melter should be stored in an area where moisture cannot enter machine heating system such as hot oil, controls, etc. Extended down time can cause moisture build up in heating oil tank.

If there is any suspicion that moisture may have collected in heat transfer oil, warm heat transfer fluid to 300° F. for 2 to 3 hours to evaporate the moisture.

## INSTRUCTIONS FOR ORDERING PARTS

Parts may be ordered from your local CRAFCO™ distributor or directly from CRAFCO™, Inc. if a distributor is not available in your area. When ordering parts, give the following information:

- a. Part Number.
- b. Machine Model.
- c. Serial Number from Name Plate.

Write or telephone:

CRAFCO™, Inc.  
235 S. HIBBERT DR.,  
MESA, AZ 85210  
Phone: (602) 655-8333  
Toll Free: 1-800-528-8242

## ELECTRIC HOSE CARE AND CAUTIONS

Twisting and kinking of the electric hose (used on LF, BAX, SS60, and SS125 Melters) is the number one cause of hose failure.

When this happens, the electric heating wires are shorted out to the metal hose cover and the hose stops heating.

**This type of failure is not covered under the CrafcO™ warranty.**

To help prevent twisting and kinking and the resulting hose damage, the operator should:

- a. Do not move or use hose unless it has been turned on a least 35 minutes and set at a minimum temperature of 300° F.
- b. Make sure hose swivel between hose and wand moves freely.
- c. Limit the hose bending to a radius of 10 inches.
- d. Avoid bending the hose over sharp edges such as the edge of the frame or tank.
- e. Avoid twisting.
- f. Do not exceed 400° F. on the hose controller or material temperature.
- g. Follow all instructions of the melter as well as those in the instruction manual.

## HOSE TRANSPORT INSTRUCTIONS

1. Remove hose from jib support and rotate jib support towards front of machine until it locks into position.
2. Wrap hose on hose hanger two complete wraps (Approximately 20 inch diameter).
3. Store wand in support hook.

### **CAUTION:**

Hose damage will occur if:

- a. Hose is bent or moved when cold.
- b. Hose is twisted or bent at less than 10 inch radius.
- c. Hose is moved prior to being turned on at least 35 minutes and set at 380 degrees F.
- d. Operator crosses over or under hose causing hose to twist or wires between hose and wand connection to twist or wrap up.
- e. Swivel is cold and not free to move allowing hose to twist.
- f. Hose to wand wiring is pulled, stressed, or used to support the wand.

## MAINTENANCE INSTRUCTIONS

### ENGINE

See engine owners manual for operating and maintenance instructions.

### HYDRAULIC SYSTEM

Check hydraulic fluid daily. Change hydraulic filter after first 10 hours of operating and every 250 hours thereafter. Change hydraulic fluid every 500 hours of operation.

### WHEEL BEARINGS

Re-pack wheel bearings every 24,000 miles or every two years, using a good grade of bearing grease.

### TONGUE JACK

Lubricate tongue jack, using a good grade of bearing grease.

### MIXER BEARING

Lubricate every 50 hours with good quality high temperature grease.

LOCATION	PROCEDURE	HOURS			
		8	50	100	500
Engine check oil level.	See engine instruction manual.	*			
Other engine maintenance	See engine operating and maintenance instructions				
Battery	Check water level weekly				
Heat transfer oil	Check		*		
	Change				*
Hydraulic oil filter	First change (10 hours)				
	Subsequent changes (250 hours)				
Hydraulic oil	Check oil		*		
	Change oil				*
	For proper oil, see recommended fluids & lubricants.				
Wheel bearings	Clean & re-pack using a good grade of bearing grease			Every 24,000 miles or every two years	
Tongue jack	Grease, using good grade of bearing grease.			Once a year	
Air Compressor	See Air Compressor Manual.				

## SERVICE INSTRUCTIONS

1. Conduct a general inspection of your machine at least once a week. Replace all worn or damaged parts, make any necessary adjustments and tighten all loose nuts or screws.
2. Keep regular replacement items in stock for emergency repairs, to avoid costly "down" time.
3. Watch for leaks. Tighten fitting or repair as necessary.
4. Clean machine externally periodically. Check with sealant manufacturer for recommendation.
5. Follow recommended maintenance procedures on maintenance chart.

## RECOMMENDED FLUIDS AND LUBRICANTS

APPLICATION	RECOMMENDED	FULL POINT
Engine oil	Refer to Isuzu owners manual	6.7 Qts.
Diesel	#1 Cold climate #2 Warm climate	32 Gals.
Hydraulic oil	Rondo oil - HD - 68 Texaco	32 Gal.
Heat transfer oil	Regal R&O 68	34 gal.
Air Compressor	Refer to Compressor Manual	

The following is a list of suitable Heat Transfer Oil to be used in Crafcro equipment.

PRODUCER	PRODUCT NAME	PRODUCT NO.
Texaco	Regal	R & O 68
Exxon	Caloria	HT 43
Arco	Rubliene	-
Citgo	Sentry	R&O 68
Gulf Oil Co.	Security	R&O 68
Shell Oil Co.	Therma	C
Chevron Oil Co.	Chevron Heat Tranfer Oil	-
Conoco	Heat Transfer Oil	R&O 68

### TYPICAL SPECIFICATIONS

ISO	68	Viscosity Index	95-100
Flash Point, COC	445° F.	Pour Point	0° F.
Viscosity @ 100° F.-SUS	325	Carbon Residue	1%
Viscosity @ 210° F.-SUS	50		

### WARNING

The Heat Transfer Oil in this machine is a grade that has been tested and recommended by Crafcro™, Inc. The addition of any grade of oil not specifically recommended by Crafcro™, Inc., shall be cause for voidance of all warranties.

All oils subjected to high temperatures deteriorate with time and lose many of their characteristics. Tests conducted by Crafcro™, Inc. have determined that for best results and safety, the Heat Transfer Oil in this machine must be drained and replaced with Crafcro™, Inc. recommended oil after five hundred (500) hours of operation or one (1) year, whichever occurs first.

## SUPER SHOT PUMP REPLACEMENT

### Step 1

Bring melter up to temperature as preparation for draining the material tank. Remove pipe cap located at rear of machine and drain tank ( **CAUTION!!! EXTREMELY HOT MATERIAL**).

### Step 2

Remove both guards from the motor mount bridge for access to chain and sprockets.

### Step 3

Rotate agitator until connecting link is accessible. Disassemble the connecting link and remove the drive chain.

### Step 4

Loosen the set screw in the lower coupling half between the hydraulic motor and the drive shaft.

### Step 5

Remove the (4)hydraulic hoses and cap off all ports. **Note:** Mark hoses for ease of replacement.

### Step 6

Remove the (4) bolts holding motor mount bridge to top of melter. Lift off motor mounting bridge and set aside.

### Step 7

Remove (2) bolts holding agitator shaft bearing. **Note:** Do not remove bearing from agitator shaft.

### Step 8

When unit has cooled sufficiently, Remove (6) bolts holding paddles to top of screen. Remove paddles from tank.

### Step 9

Remove pump drive shaft from center of agitator shaft then lift agitator shaft and screen assembly as high as possible and insert screw driver into shaft hole. This will support this assembly while removing the pump from the tank.

### Step 10

Remove the (6) bolts which fasten the pump to the tank. Lift the pump from the material tank (**CAUTION !!! THE PUMP WEIGHS APPROXIMATELY 90 Lbs.**).

### Disassembly of material pump

### Step 11

Remove the (2) bolts which hold the pump plates together. disassemble the (3) plates from each other (**Note: as pump is being disassembled make note of the orientation of holes in each plate**).

### Step 12

Clean all pump parts thoroughly before beginning to reassemble the pump.

### Step 13

Assemble the pump, check for free movement of the pump gears. If gears do not turn freely, loosen bolts slightly and align plates until the gears turn freely. Torque all the bolts to 35 Ft. Lbs.

### Step 14

Install all parts in machine starting from **Step 10** and working backwards to **Step 1**.

## UNLOADER ADJUSTMENT INSTRUCTIONS

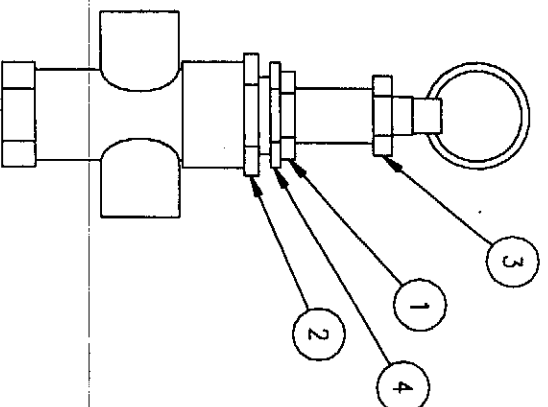

1. Remove safety valve from tee fitting on tank and install a pressure gauge.
2. Loosen jam nuts #1 and #2.
3. The unloading pressure can be adjusted by screw #3, Turn clockwise to increase and counterclockwise to decrease pressure.
4. The differential pressure (difference between cut-in and cut-out pressure) is obtained by adjusting screw #4. Turning clockwise will widen the differential and counterclockwise will narrow the differential.
5. Repeat items #2 and #3 until the unload pressure is set at 100 PSI, and the differential pressure is set at 80-85 PSI.
6. After adjustments are made, tighten jam nuts #1 and #2.



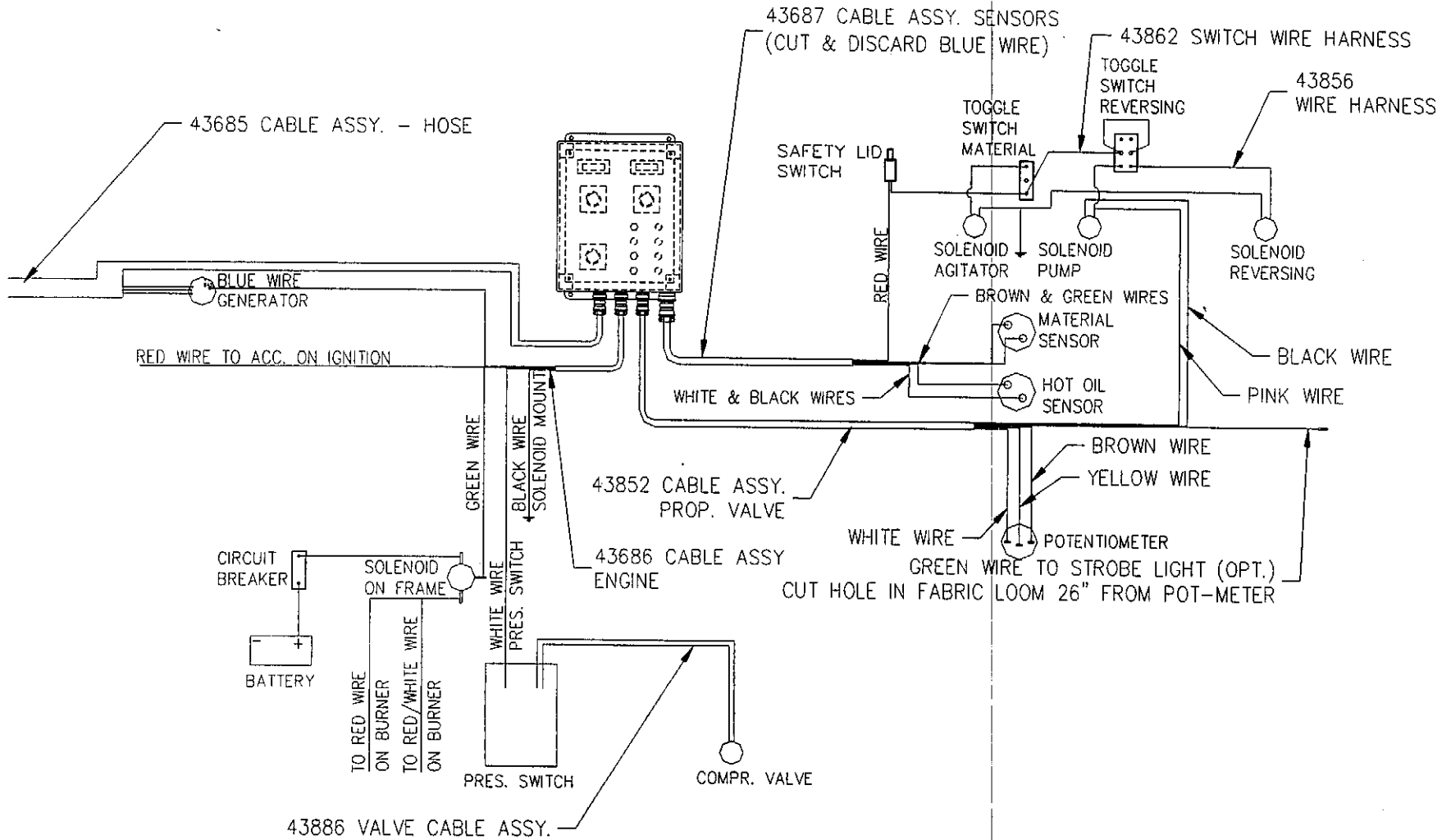

## SS125 AND SS60 HOSE AND WAND

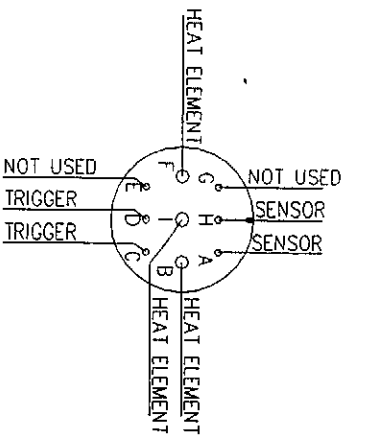

KETTLE END

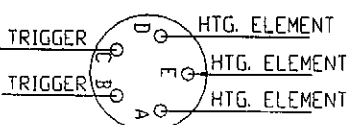

WAND END

### **Hose is not heating**

1. Check continuity between "F", "I" and "B" while wand is connected. Also check for continuity to the case. There should not be any continuity to the case.
2. If there is no continuity in one of the ports, disconnect wand and check "A", "E" and "D" on wand connector, then check "A", "E" and "D" to "F", "I" and "B" on ends of hose.
3. If all of the above checks OK, then check the resistance of the sensors between "A" and "H" on kettle end of the hose, it should read 1.01 K Ohms. If there is no resistance then the sensor is bad. **NOTE!** : The resistance will be higher if the hose is warmer than 70 degrees.

4. If digital LED is reading "1", that means there is a open circuit in the sensor. If the LED is reading "-1", that means there is a short in the sensors. If the LED is reading a high temperature, then the sensor wires are receiving voltage from another wire. If the LED is reading a negative number, then the resistance is lower than 1000 ohms.

### **Pump not operating**

1. If trigger is not working, check continuity between "D" and "C" (kettle end) when trigger is pulled. If no continuity disconnect wand and check "C" and "B" (wand end). If there is no continuity then switch is bad.
2. If there is continuity, then disconnect the cable on the far left and check "B" on the control box to see if you have 12 volts going to the driver card in the control box. The card has a light in the upper left corner which will be illuminated when there is 12 volts.
3. If you have 12 volts at the driver card, then check "MIN." on the driver card. Take voltage between coil and coil- when potentiometer at the rear of the machine is turned to the far left. The voltage should be 1.5 volts. If not, set "MIN." potentiometer on the driver card by turning counter clockwise to lower the voltage and clockwise to increase the voltage. Next check the "MAX." voltage on the driver card. Take voltage between coil+ and coil- when potentiometer at rear of machine is turned to the far right. The voltage should be 10.5 volts. If not, set "MAX." potentiometer on the driver card (same as "MIN.").
4. **NOTE:** The electrical plugs on the hydraulic valves have a light which tells you if there is 12 volts to the coil. There is also a light on the driver card inside the control box which tells when there is 12 volts going to the card (SS125 ONLY).

## HOSE TROUBLE SHOOTING

PROBLEM	CAUSE	REMEDY
Hose does not heat	Generator wire loose.	Tighten nut.
	Generator belt loose.	Tighten belt.
	Bad connection at control box.	Tighten plug.
	Bad connection between hose and wand.	Tighten plug.
	Hose kinked and shorted wires.	Replace hose.
	Generator not producing voltage.	Replace generator.
	Bad sensor in hose.	Send to Craftco for repair.
Hose heats partially	Hose kinked and wires shorted.	Replace hose.
Hose light flickers	Bad Pak-Stat (Temp. Controller)	Replace Pak-Stat
Material does not dispense from hose	Bad wire connection.	Repair loose wire.
	Bad switch	Replace switch.
	Cartridge failure on hydraulic valve.	Replace cartridge on valve.
	Coil failure on hydraulic valve.	Replace coil on valve.
	Driver card not set properly.	Set driver card.
LED Readout is incorrect	Open circuit on the sensor	Repair broken or loose wire.
	Short in the sensor	Replace bad wire.
	Sensor resistance below 1000 ohms.	Replace sensor.
	Polarity of plug to Pak-Stat	Check for P1 to 1 connection.

1. □ WIRE NUT

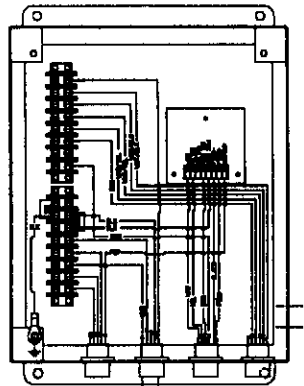

IGNITION SWITCH  
RED WIRE TO  
ACC TERMINAL

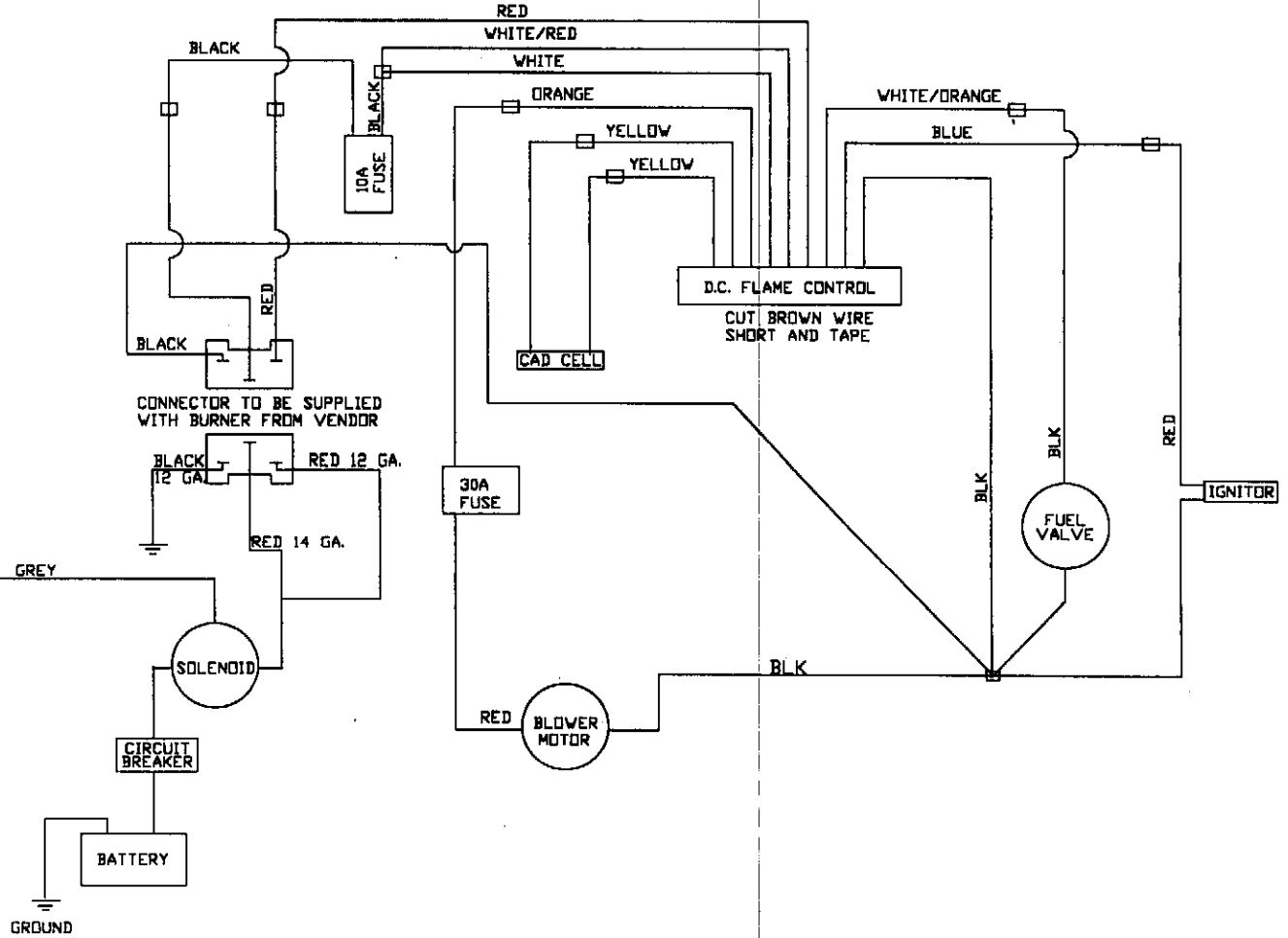

## BURNER TROUBLE SHOOTING

### BURNER WILL NOT IGNITE

**Step 1:** Check for 12 volts at burner toggle switch.

**No:** Engine key "OFF"  
Toggle switch "OFF"  
Blown fuse  
Broken wire

**YES:** 12 volts at terminal #7 on "material" thermostat

**NO:** Bad thermostat  
Faulty sensor

**YES:** Check for 12 volts at terminal #7 on "OIL " thermostat

**NO:** Bad thermostat  
Faulty sensor

**YES:** Check for 12 volts at solenoid (frame) terminal to burner

**NO:** Bad solenoid  
Bad connection at battery  
Faulty circuit breaker  
Broken or loose wire

**YES:** Faulty DC Controller, poor ground / loose wire  
Faulty or dirty flame  
Faulty ignitor transformer, cracked electrode (ceramic)  
Incorrect ignitor gap  
Faulty fuel solenoid  
Bleed fuel pump / check fuel pump coupling  
Fuse under DC Controller  
Blower motor relay  
Faulty blower motor  
Alternator not charging @ 14 volts  
Faulty 12 volt battery

### BURNER LIGHTS BUT SHUTS DOWN AFTER 15 SEC.

Faulty flame eye  
Broken, loose flame eye sensor wires, receptacle  
Faulty DC Controller

### BURNER LIGHTS BUT WILL NOT RELIGHT

Bad connection at battery  
Broken or loose wires  
Faulty DC Controller  
Alternator not charging at 14 volts  
Faulty 12 volt battery

### EXCESSIVE SMOKE FROM BURNER EXHAUST

Air vent incorrectly set - set at 5  
Blower motor not turning at correct speed  
Alternator not charging at 14 volts  
Faulty 12 volt battery

## TROUBLE SHOOTING HYDRAULICS

PROBLEM	CAUSE	REMEDY
Mixer will not rotate	Sealant temperature too low. Too many blocks placed at one time.	Continue to heat material. Continue to heat material
	Inadequate hydraulic flow/ pressure. Toggle switch turned off.	Check hydraulic fluid level. Reset pressure, check flow if necessary.
Material pump will not rotate.	Material in tank not to operating temperature. Inadequate hydraulic flow/ pressure.	Continue heating material. Check hydraulic fluid level. Reset pressure, check flow as necessary.
	Material pump damaged. Foreign object lodged in pump. Temperature at wand tip is inadequate. Bad switch at wand. Hydraulic cartridge failure. Hydraulic coil failure. Less than 10.5 V @ driver card. Driver card not set properly	Remove and replace. Remove pump, clean & replace. Set wand tip inside material tank. Remove and replace. Remove and replace. Remove and replace. Remove and replace. Charge or replace battery. Set min. and max. voltage.
When applying sealant it stops flowing from applicator wand.	Tank fluid level to low for material to flow into pump	Add more material or continue heating material until more liquid material is available.
Pump rotates, but will not pump material.	Material cold, inlet still solid Hose not to temperature. Temperature at wand tip is inadequate.	Continue to heat material. Allow to heat longer. Set wand tip inside material tank.
Pump does not rotate	Bad wire connection. Bad switch at wand handle. Hydraulic cartridge failure. Hydraulic coil failure.	Find and repair. Remove and replace Remove and replace Remove and replace
Slow heat up of sealant	Build up of coked material on inside of material tank. Burner not operating / low LPG pressure Low heating oil level. Low heating oil temperature	Allow machine to cool. Remove deposits and flush with solvent. Repair / Adjust Make sure fluid level is correct. Set at recommended temperature.

MIXER TO TURN C'CLOCKWISE  
MATL PUMP CLOCKWISE  
HYD PRESSURE- 1800 PSI  
PUMP FLOW- 22.0 GPM

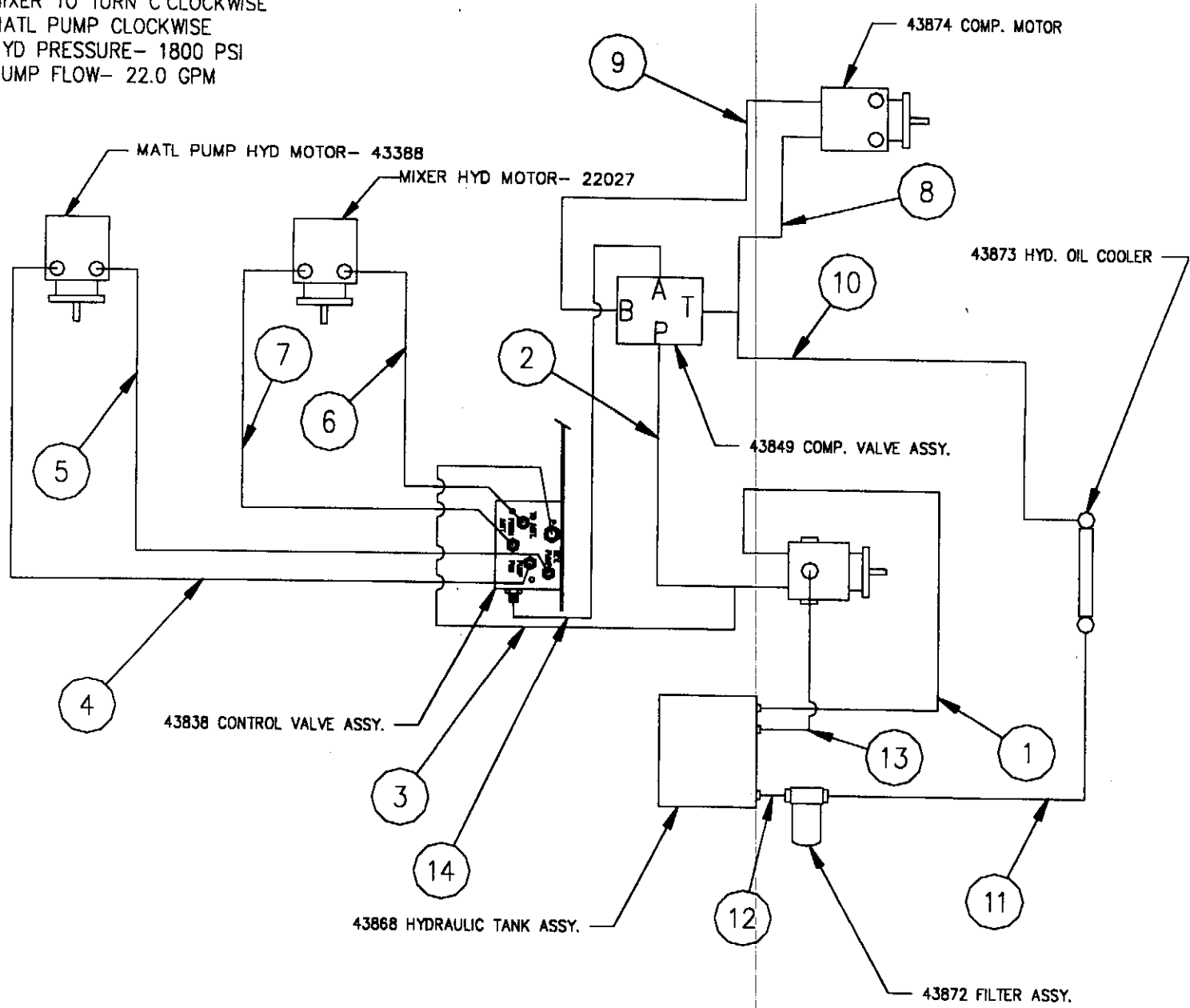

43874 COMP. MOTOR

9

8

MATL PUMP HYD MOTOR- 43388

MIXER HYD MOTOR- 22027

43873 HYD. OIL COOLER

10

A  
B  
P  
T

43849 COMP. VALVE ASSY.

5

7

2

6

43838 CONTROL VALVE ASSY.

4

3

13

1

14

43868 HYDRAULIC TANK ASSY.

12

11

43872 FILTER ASSY.

<b>1. HYDRAULIC RESERVOIR TO HYDRAULIC PUMP (SUCTION)</b>	
1	29969 90 Deg. Elbow 1 1/4 NPT x 1 1/4 Tube
1	29507 Hydraulic Hose Assembly 1 1/4 x 30" Lg.
1	29985 Straight Adapter 1 5/8-12 O-Ring
<b>2. HYDRAULIC PUMP PRESSURE TO COMPRESSOR "P"</b>	
1	29918 Female Straight O-Ring Reducer
1	29964 3/4 Male Run Tee
1	29525 Hydraulic Hose Assembly 3/4 x 20"
1	29862 Straight Thread O-Ring 90 Deg. Elbow
<b>3. HYDRAULIC PUMP PRESSURE TO CONTROL VALVE "P" PORT</b>	
1	29526 Hydraulic Hose Assembly 1/2 x 70"
1	29897 Straight Thread O-Ring Adapter
<b>4. HYDRAULIC VALVE "PMP FWD" TO HYD. MOTOR (MATL PUMP)</b>	
1	40311 Straight Thread O-Ring Adapter
1	29538 Hydraulic Hose Assembly 3/8 x 24"
1	22029 Straight Thread O-Ring Adapter
<b>5. HYDRAULIC MOTOR (MATL PUMP) TO HYD. VALVE "PUMP REV."</b>	
1	22029 Straight Thread O-Ring Adapter
1	29539 Hydraulic Hose Assembly 3/8 x 27"
1	40311 Straight Thread O-Ring Adapter
<b>6. HYDRAULIC VALVE "TO AGIT" TO HYD. MOTOR (MIXER)</b>	
1	40311 Straight Thread O-Ring Adapter
1	29549 Hydraulic Hose Assembly 3/8 x 20"
1	22029 Straight Thread O-Ring Adapter
<b>7. HYD. MOTOR (MIXER) TO HYD. VALVE "FROM AGIT"</b>	
1	22029 Straight Thread O-Ring Adapter
1	29518 Hydraulic Hose Assembly 3/8 x 16"
1	40311 Straight Thread O-Ring Adapter
<b>8. MIXER MOTOR (COMP.) TO "T" PORT COMP. VALVE</b>	
1	29916 Straight Thread O-Ring 90 Deg. Elbow
1	29527 Hydraulic Hose Assembly 3/4 x 32"
<b>9. COMPRESSOR VALVE "B" TO HYD. MOTOR (COMP)</b>	
1	29862 Straight Thread O-Ring 90 Deg. Elbow
1	29528 Hydraulic Hose Assembly 5/8 x 39"
1	29862 Straight Thread O-Ring 90 Deg. Elbow
<b>10. COMPRESSOR VALVE "T" PORT TO HYD. OIL COOLER</b>	
1	22028 Straight Thread O-Ring Adapter
1	29970 3/4 Swivel Nut Branch Tee
1	29524 Hydraulic Hose Assembly 3/4 x 86"
1	29916 Straight Thread O-Ring 90 Deg. Elbow
<b>11. OIL COOLER TO HYDRAULIC FILTER</b>	
1	29916 Straight Thread O-Ring 90 Deg. Elbow
1	29523 Hydraulic Hose Assembly 3/4 x 76"
1	29878 90 Deg. Elbow Adapter 3/4 NPT x 3/4 Tube
1	28353 Reducer Bushing 1 1/4 NPT x 3/4 NPT
<b>12. FILTER TO RESERVOIR</b>	
1	28006 Nipple 1 1/4 Close



MIXER TO TURN C'CLOCKWISE  
MATL PUMP CLOCKWISE  
HYD PRESSURE- 1800 PSI  
PUMP FLOW- 22.0 GPM

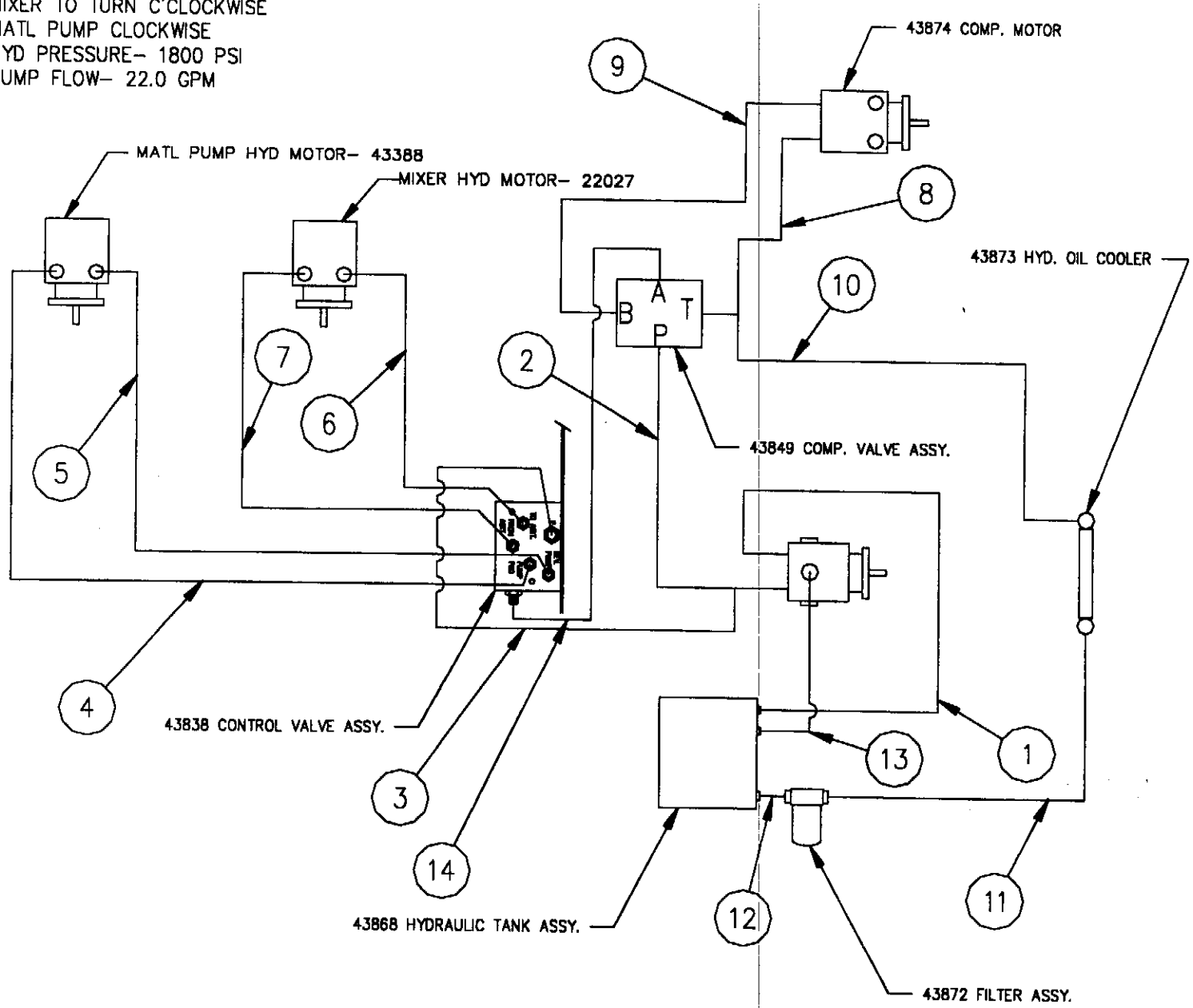

13. PUMP CASE DRAIN TO RESERVOIR		
1	29896	Straight Thread O-Ring 90 Deg. Elbow
1	29529	Hydraulic Hose Assembly 1/2 x 36"
1	40322	90 Deg. Elbow Adapter 1/4 NPT x 3/8 Tube
2. HYDRAULIC VALVE "T" PORT TO COMPRESSOR VALVE "A" PORT		
1	40309	Female Straight O-Ring 90 Deg. Elbow
1	29535	Hydraulic Hose Assembly 3/4 x 20"
1	29868	Straight Thread O-Ring 90 Deg. Elbow

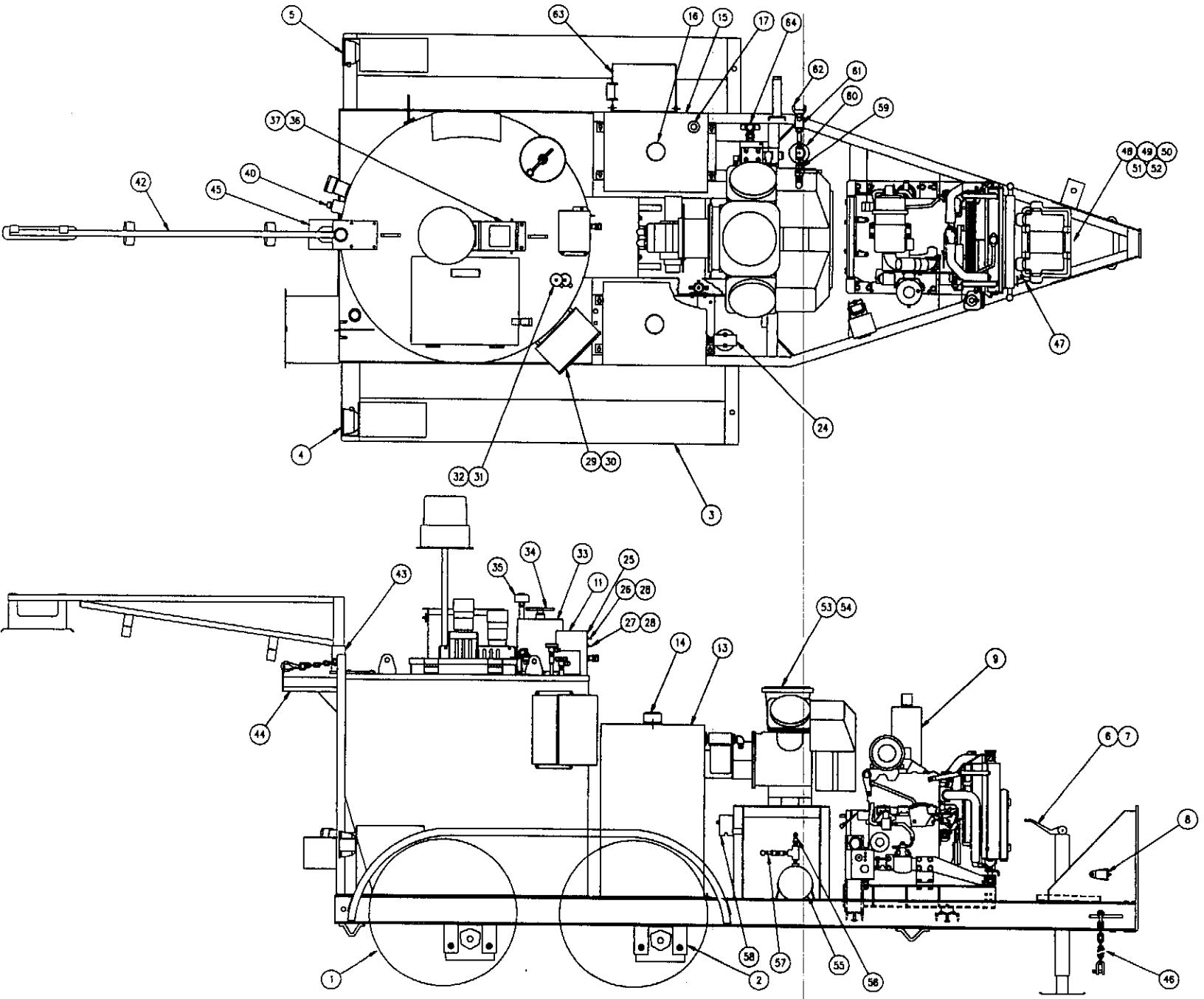

NUMBER	PART NUMBER	DESCRIPTION	QTY.
1	41743	Tire and wheel assembly	4
2	43616	Torsional axle assembly	2
3	41170	Fender assembly - L.H.	2
4	24022	Tail light - R.H.	1
5	24023	Tail light - L.H.	1
6	23082	Tongue jack	1
7	23095	Swivel bushing - tongue jack	1
8	23117	Breakaway switch	1
9	43848	Engine assembly	1
10	29399	Isomount	4
11	43841	Cover - control valve	1
12	39602	Solenoid	1
13	43595	Hydraulic tank assembly	1
14	43424	Filler / Breather with dipstick	1
15	43812	Fuel tank assembly	1
16	43425	Filler / Breather - fuel tank	1
17	29398	Fuel level gauge (Optional)	1
18	41891	14 Volt burner	1
19	41883	Nozzle - burner	1
20	41893	Burner cover	1
21	41886	Transformer	1
22	41890	Blower motor	1
23	41888	Fuel solenoid	1
24	43870	Hydraulic filter assembly	1
25	43818	Bracket - control valve	1
26	32513	Toggle switch - pump reverse	1
27	50719	Toggle switch - agitator	1
28	50720	Boot - switch	2
29	43669	Control box assembly	1
30	50074	Spacer - control box	4
31	43465	Sensor	2
32	51065	Cord grip	2
33	43355	Overflow tank	1
34	43673	Dipstick	1
35	26025	Air breather	1
36	43427	Pump / Agitator motor assembly	1
37	43307	Chain guard assembly	2
38	24095	Strobe light (Optional)	1
39	43672	Mounting bracket - strobe light	1
40	42796	Cover - potentiometer	1
41	43845	Potentiometer	1
42	43828	Boom	1
43	43836	Boom base	1
44	43827	Hose hanger assembly	1

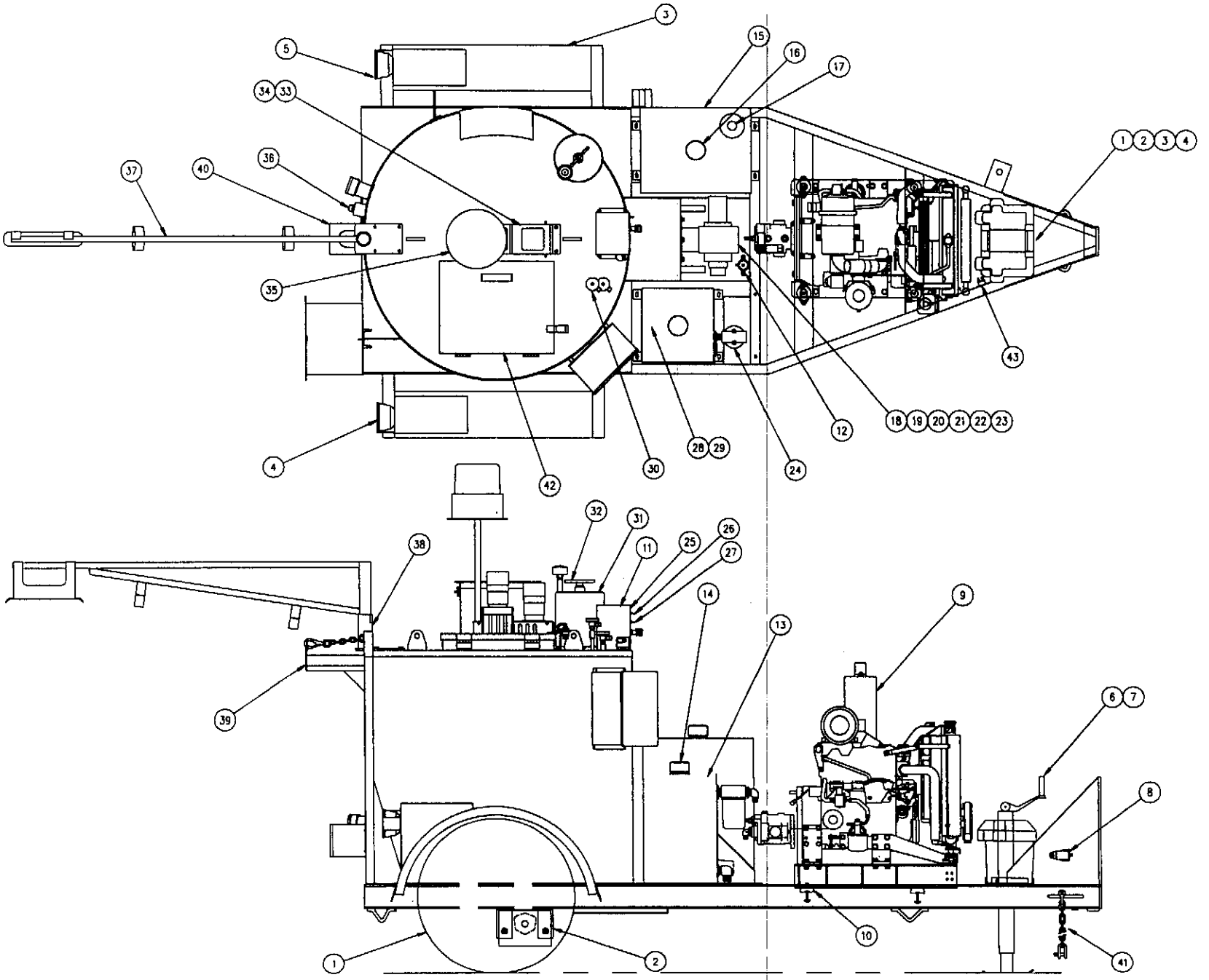

NUMBER	PART NUMBER	DESCRIPTION	QTY.
45	43812	Heat guard	1
46	20130	Safety chain	2
47	31512	Circuit breaker	1
48	24000	Battery	1
49	24002	Battery box	1
50	27174	Battery cable - (-) 27"	1
51	24015	Battery cable - (+) 38"	1
52	37038	Battery cable - ground	1
53	43879	Air compressor assembly	1
54	43876	Isolation pad	4
55	42624	Air tank	1
56	42629	Safety valve	1
57	42628	Unloader valve	1
58	42621	Pressure control valve	1
59	29214	1/2" Ball valve	1
60	42603	Water separator	1
61	42702	1/2" Swivel adapter	1
62	42643	1/2" Air hose fitting	1
63	43842	Drip pan	1
64	43849	Hydraulic valve - compressor	1

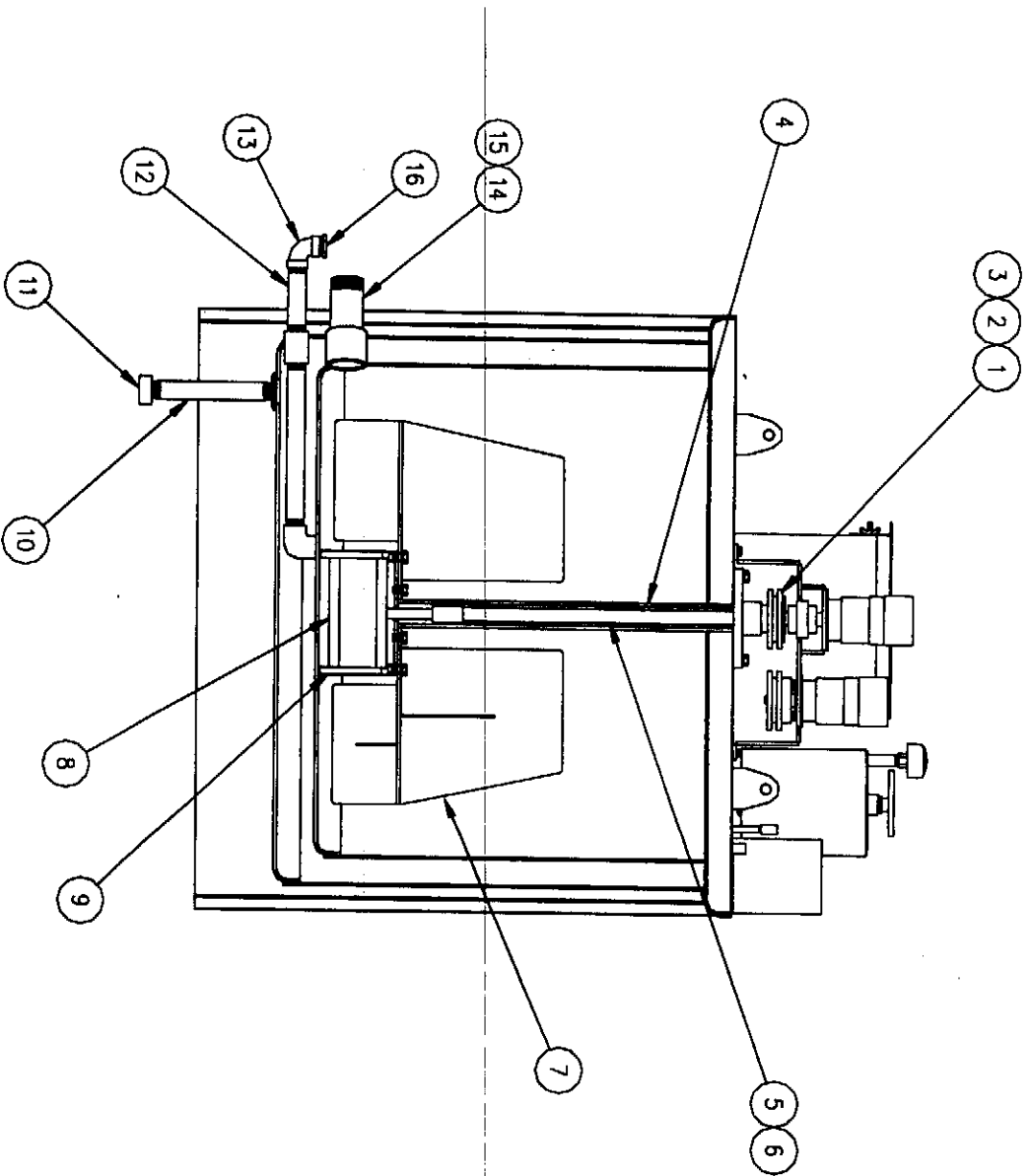

TANK DETAIL

TANK DETAIL

NUMBER	PART NUMBER	DESCRIPTION	QTY.
1	43322	Sprocket - Driven	1
2	43321	Chain - Drive	1
3	43322	Connecting Link - Chain	1
4	43639	Mixer Shaft	1
5	43641	Drive Shaft - Pump	1
6	31368	Key, 1/4 Sq. x 7/8 Lg.	1
7	43649	Paddle Assembly	2
8	43677	Pump Assembly	2
9	43655	Strainer Assembly	1
10	28132	1" x 10" Lg. Pipe Nipple	1
11	28270	1" Pipe Cap	1
12	28039	1" x 4" Lg. Pipe Nipple	1
13	28210	90 Deg. Elbow	1
14	28046	2" x 4" Lg. Pipe Nipple	1
15	28273	2" Pipe Cap	1
16	28351	1" x 3/4" Reducer Bushing	1



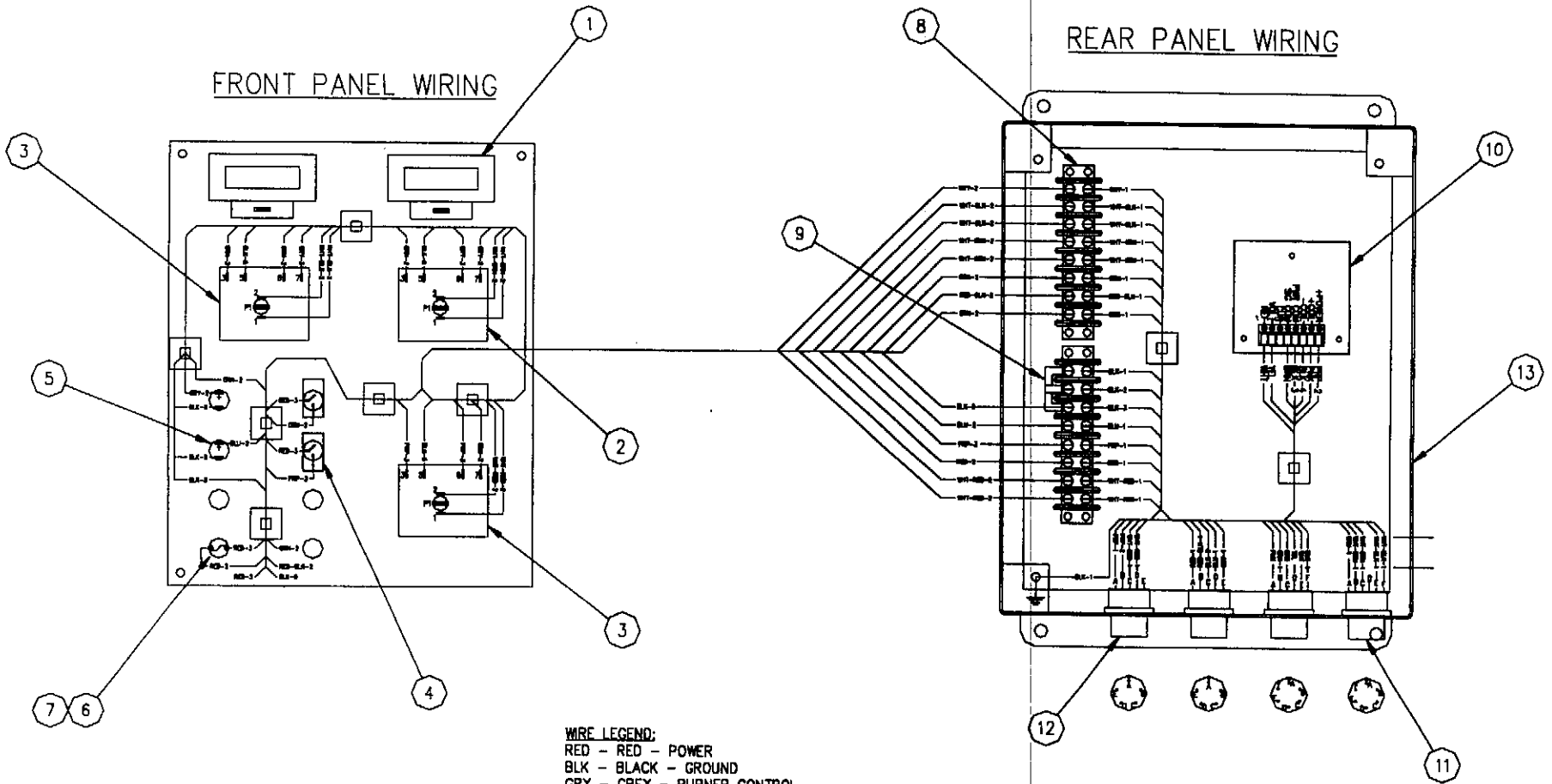

**WIRE LEGEND:**  
 RED - RED - POWER  
 BLK - BLACK - GROUND  
 GRY - GREY - BURNER CONTROL  
 ORN - ORANGE - OIL/MAT-L CONTROLS AND MIXER  
 PRP - PURPLE - HOSE CONTROL AND DRIVER CARD  
 BLU - BLUE - GENERATOR CONTROL  
 GRN - GREEN - BEACON LIGHT (OPT.)  
 RED-BLK - RED/BLACK - COMPRESSOR CONTROL (OPT.)  
 WHT-BLK - WHITE/BLACK - MAT'L SENSOR  
 WHT-GRN - WHITE/GREEN - OIL SENSOR  
 WHT-RED - WHITE/RED - HOSE SENSOR  
 WHT - WHITE - DRIVER CARD "REF"  
 YEL - YELLOW - DRIVER CARD "VOLT"  
 BRN - BROWN - DRIVER CARD "SIG COM"  
 PNK - PINK - DRIVER CARD "COIL+"

**CONTROL BOX ASSEMBLY**

<b>NUMBER</b>	<b>PART NUMBER</b>	<b>DESCRIPTION</b>	<b>QTY. REQ'D</b>
1	50251	Digital readout	2
2	43391	Pak-Stat temperature controller (150-550)	1
3	43397	Pak-Stat temperature controller (200-400)	2
4	50719	Toggle switch	2
5	51651	Light	2
6	24185	Fuse holder	1
7	51652	Fuse 10 Amp	1
8	50250	Terminal strip	2
9	50238	Jumper	2
10	43846	Driver card	1
11	50517	Receptacle 6-pin	2
12	50215	Receptacle 5-pin	2
13	43665	Enclosure	1

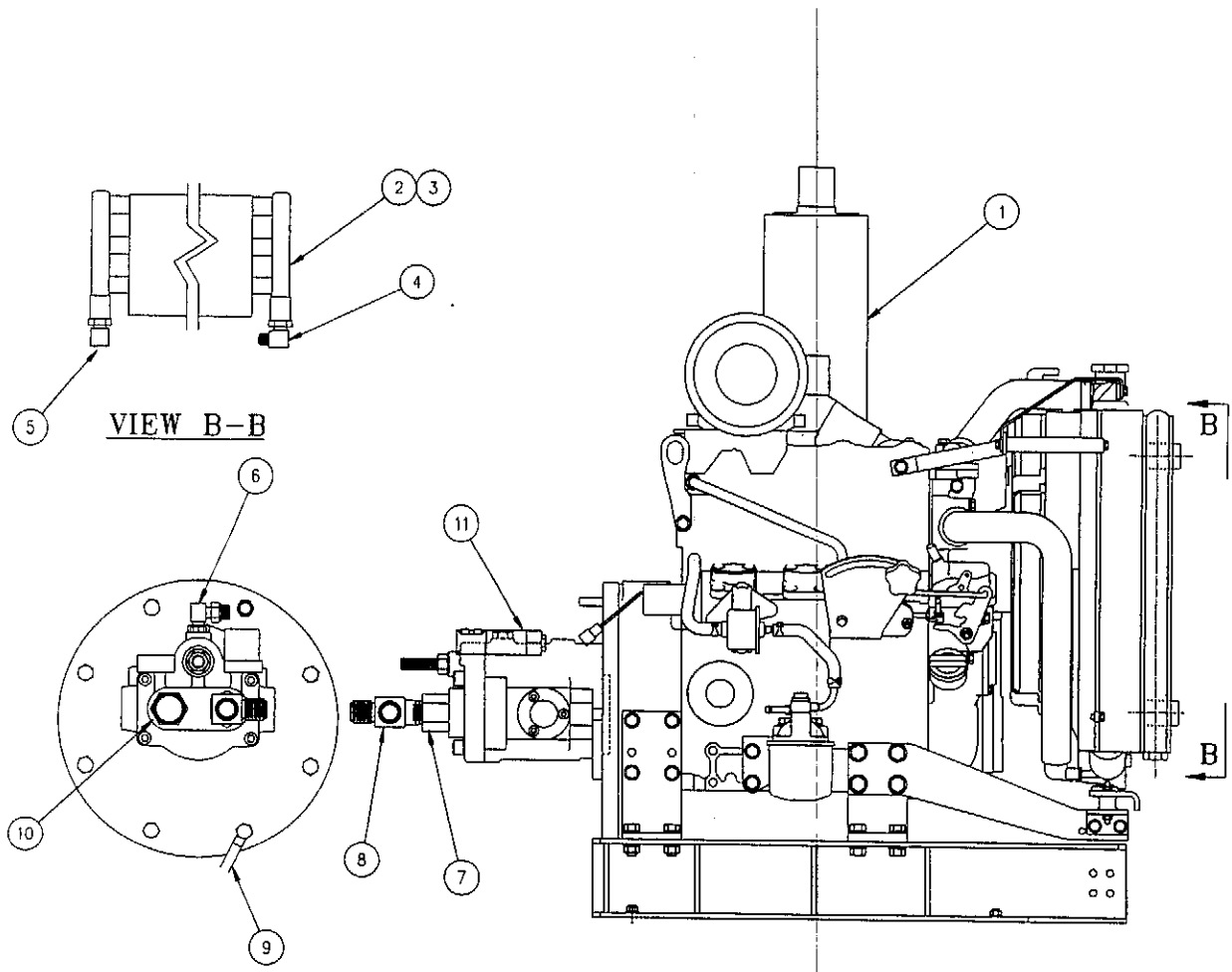

## ENGINE ASSEMBLY

NUMBER	PART NUMBER	DESCRIPTION	QTY.
1	43869	37 HP Engine	1
2	43873	Hydraulic Oil Cooler	1
3	42657	Mounting Kit - Oil Cooler	2
4	29916	Straight Thread O-ring 90 Deg. Elbow	1
5	29916	Straight Thread O-ring 90 Deg. Elbow	1
6	29896	Straight Thread O-ring 90 Deg. Elbow	1
7	29964	Straight Thread O-ring Reducer	1
8	29918	3/4 Male Run Tee	1
9	27174	Ground Cable	1
10	29885	Straight Thread O-ring Adaptor	1
11	43663	Hydraulic Pump	1

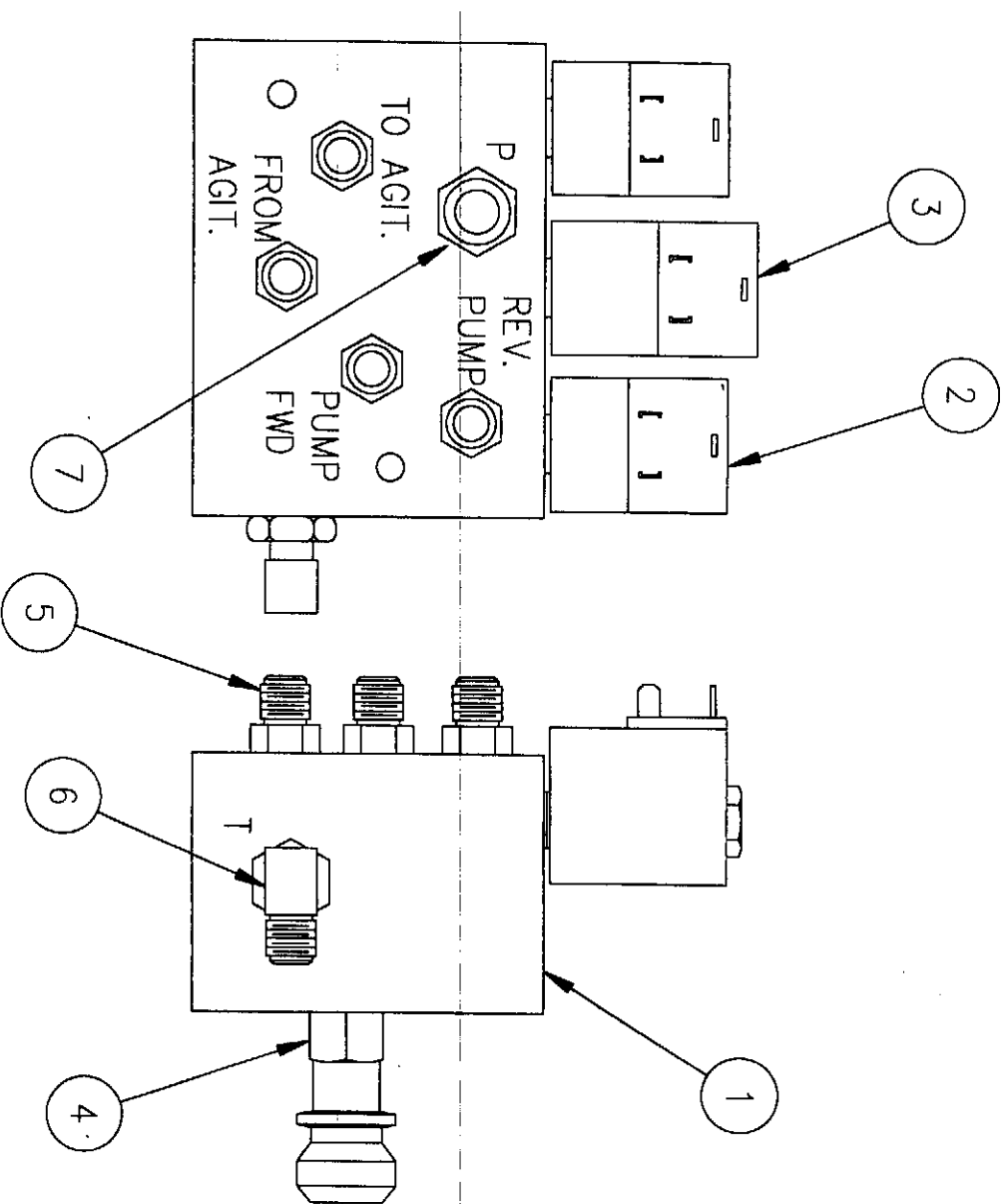

**HYDRAULIC VALVE ASSEMBLY**

NUMBER	PART NUMBER	DESCRIPTION	QTY.
1	43817	Hydraulic Valve Assembly	1
1a	43719	Cartridge Valve - Pump	1
1b	43721	Cartridge Valve - Mixer	1
1c	43722	Cartridge Valve - Reverse	1
2	43853	Coil - Control Valve	2
3	43854	Coil - Proportional Valve	1
4	43718	Flow Control - Mixer	1
5	40311	Straight Adapter	4
6	40309	Elbow Adapter	1
7	29897	Straight Adapter	1

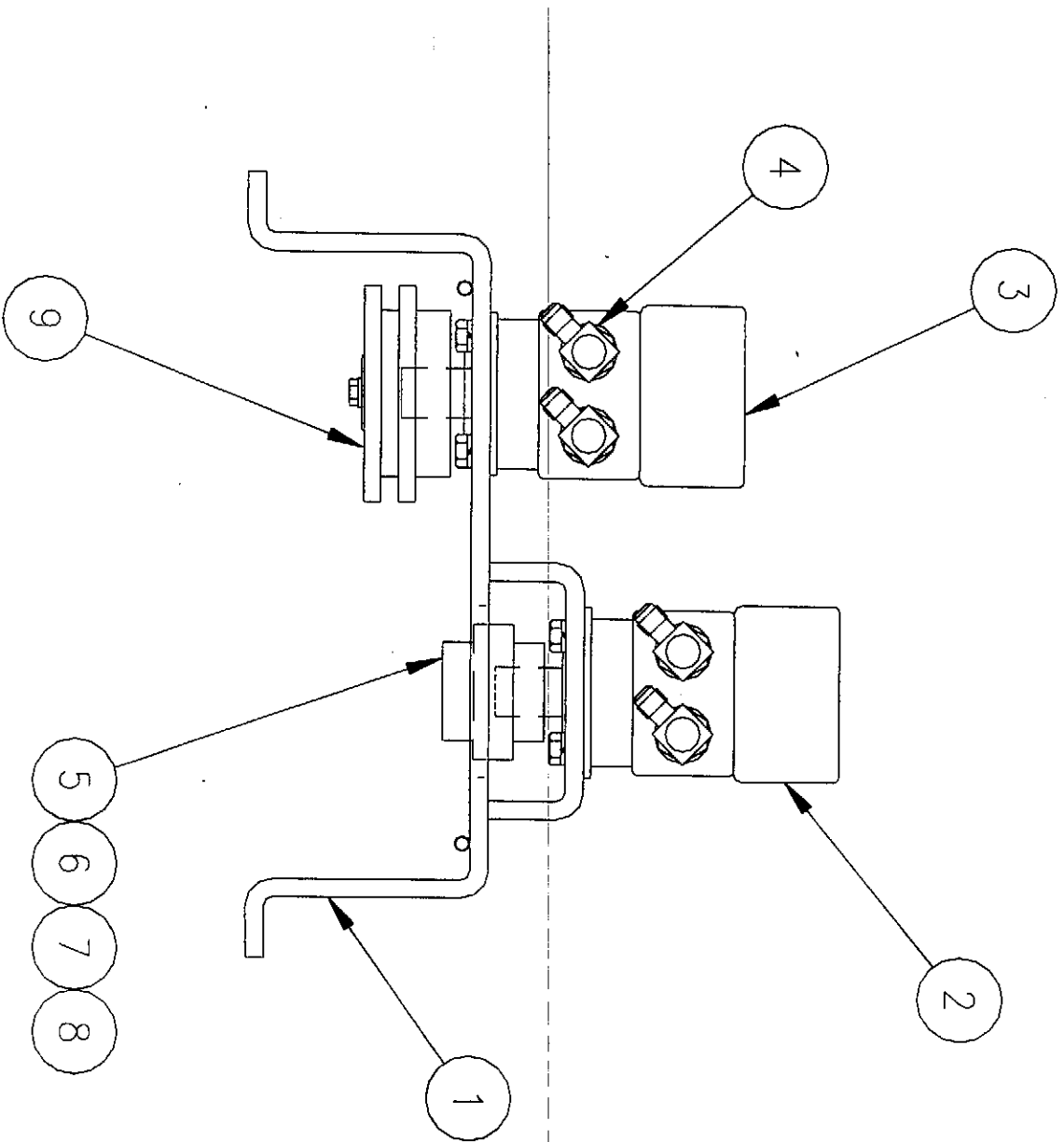

**PUMP / AGITATOR ASSEMBLY**

NUMBER	PART NUMBER	DESCRIPTION	QTY.
1	43345	Motor Mounting Bracket	1
2	43388	Hydraulic Motor - Pump	1
3	22027	Hydraulic Motor - Agitator	1
4	22029	Straight O-Ring Adapter	4
5	26002	Sprocket - Chain Coupling	2
6	26016	Chain - Coupling	1
7	26030	Connecting Link - Chain	1
8	31368	Key 1/4 X 1/4 X 7/8	1
9	43323	Sprocket - Agitator Drive	1

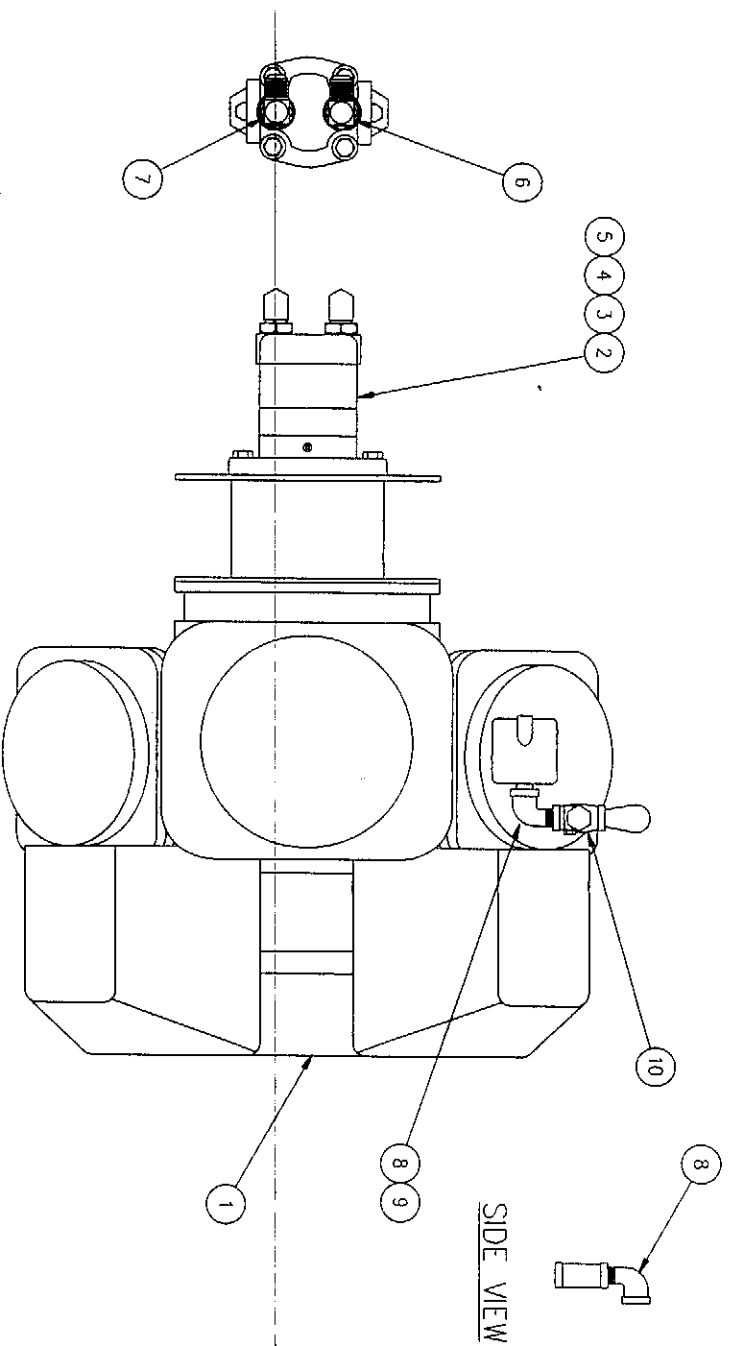

NUMBER	PART NUMBER	DESCRIPTION	QTY.
1	43875	Air Compressor	1
2	43874	Hydraulic Motor	1
3	43707	Coupling Half - Motor	1
4	43709	Coupling Sleeve	1
5	43708	Coupling Half - Compressor	1
6	29842	Straight Thread O-ring 90 Deg. Elbow	1
7	29916	Straight Thread O-ring 90 Deg. Elbow	1
8	28003	1/2" Close Nipple	1
9	28238	1/2" Street Elbow	2
9	29215	1/2" Check Valve	1

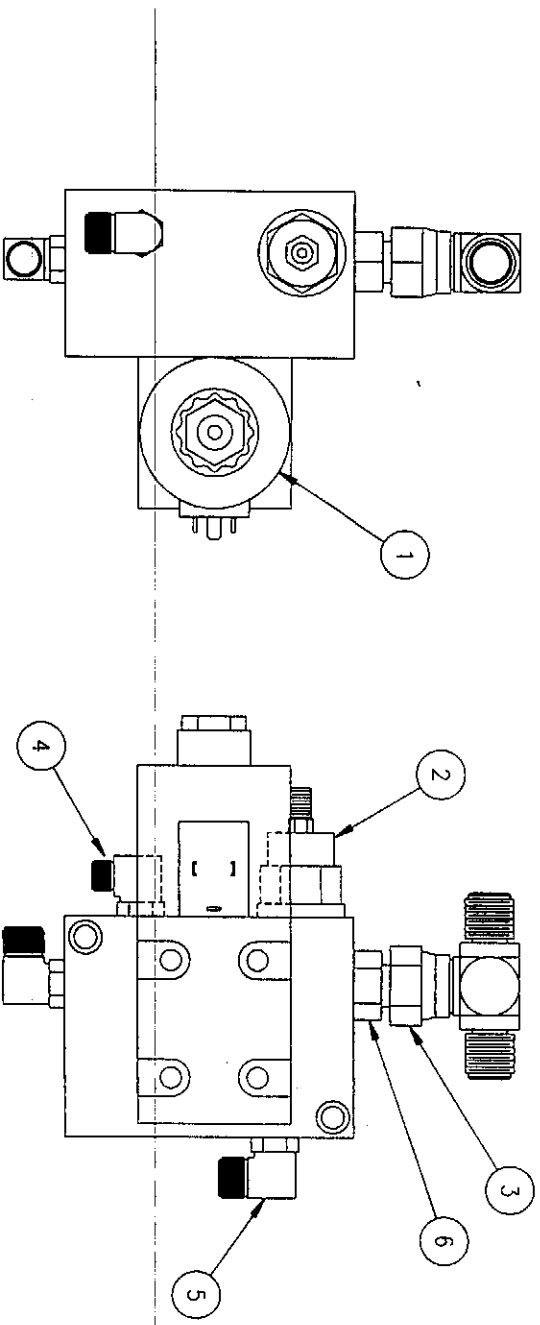

NUMBER	PART NUMBER	DESCRIPTION	QTY.
1	43717	Coil	1
2	43711	Flow Control	1
3	29970	Swivel Nut Branch Tee	1
4	29868	Straight Thread O-Ring 90 Deg. Elbow	1
5	29862	Straight Thread O-Ring 90 Deg. Elbow	2
6	22028	Straight Thread O-ring Adapter	1
7	43723	Cartridge Valve	1



**Pioneering Leadership and Innovation in  
Quality Pavement Maintenance Materials.**

**CRAFCO**<sup>TM</sup>  
**INC**  
AN **ERGONIS** COMPANY

6975 W. Crafcow Way • Chandler, Arizona 85226  
(602) 276-0406 • Watts 1 (800) 528-8242  
FAX (602) 96100513